

## By-Pass Loading Arms

OPW By-Pass Loading Arms are designed as a low-cost alternative to arms constructed of Hastelloy®, Alloy 20®, and other specialty metals used to transfer hydrochloric acid and other corrosive chemicals.

This unique design offers:

- All the ease of operation and handling advantages of conventional spring balance loaders
- Liquid by-pass of steel swivel – no liquid passes through the base swivel
- Base swivel, in conjunction with torsion spring serves as a support and carrying mechanism only
- Flow passage – consists of lined pipe, plastic pipe, and a hose suspended from the support arm
- Available in 2", 3", and 4" sizes in a variety of configurations

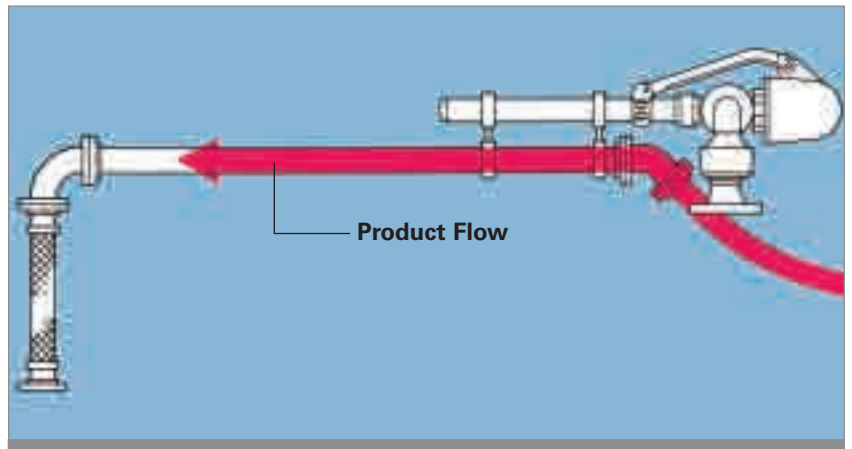

## Wash Arms

OPW Wash Arms eliminate the chore of manually carrying cumbersome, heavy hose and spray attachments to the rail car or tanker.

- Completely supports all other washing system components
- Folds into a conveniently stored position, out of the way of normal operations

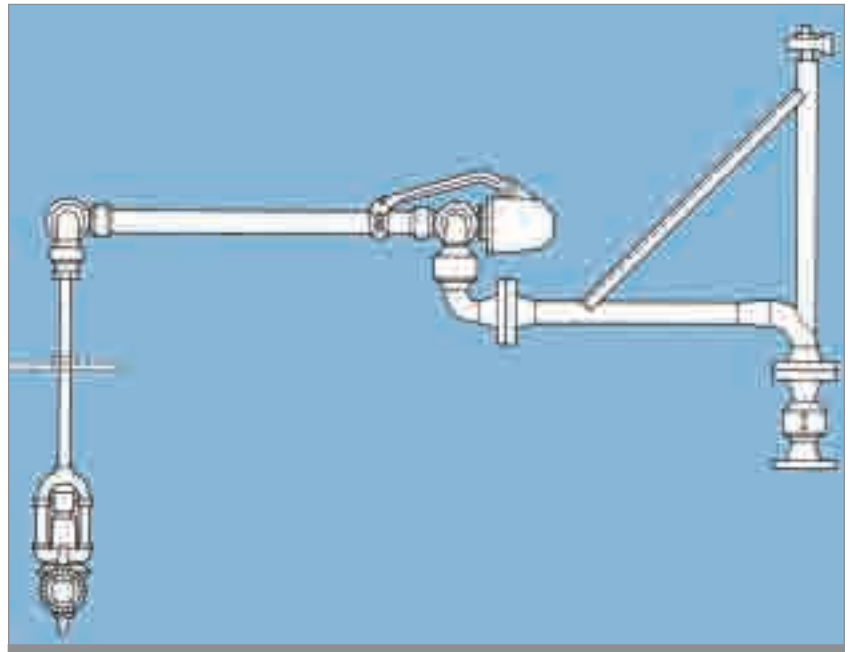

## C-33-RF Scissor Arm with Downfeed Loading

- Deadman loading valve with remote control operating lever and outlet deflector

### Remote Control Unit (1000-RC)

The OPW 1000-RC remote control unit provides convenient control of the loading valve from the outboard end of the loading arm. The 1000-RC consists of an arm clamp, lever handle and connection rod. Available for all OPW Type A, B, C, and E liquid loaders.

