

Step 1: Support and secure outboard weight of loading arm or swivel assembly with crane or lifting device while performing the following steps. It is recommended that the swivel be removed from the supporting loading arm prior to any seal maintenance. All torsion spring pre-load must be removed from torsion spring prior to any swivel joint disassembly.

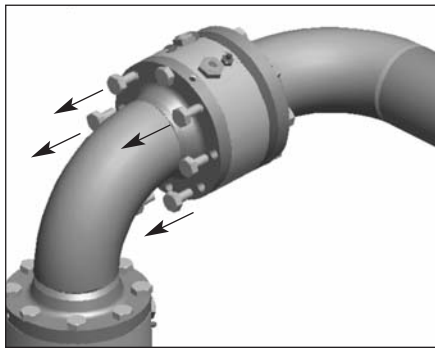

Step 2: Remove all split flange bolts on the side of the swivel attached to the free moving end. With the bolts loosened, support this side of the loading arm along with any other parts attached to it which might move freely when the bolts are removed. Remove bolts, starting with lowest on flange, leaving top bolts for last. Be careful not to damage sealing flange module face and bolts.

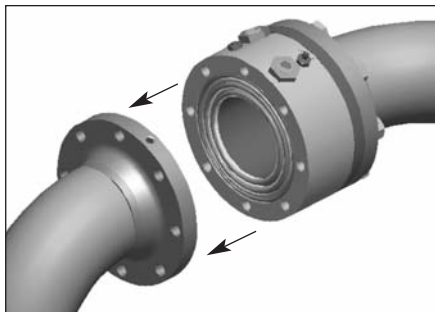

Step 3: Once the now detached arm has been secured and put out of the way, remove the three (3) O-rings and two (2) O-ring spacers. Inspect and clean all machined surfaces to ensure that there are no nicks, scratches or burrs.

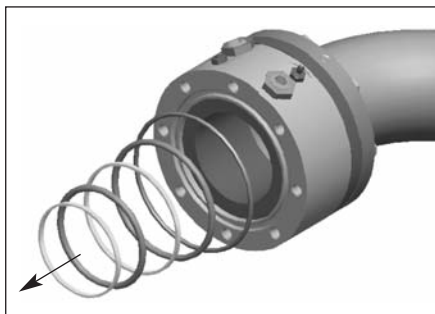

Nord-Lok™ Washers – Coarser serrations must face inward and lock together

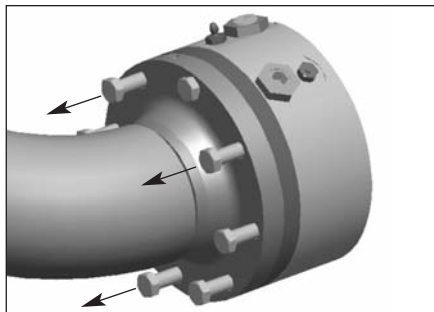

Step 4: With the rest of the loading arm still secured from movement, loosen the bolts on the other side of the swivel. Swivel module should fall away easily to expose environmental and O-ring seals. Secure product seal.

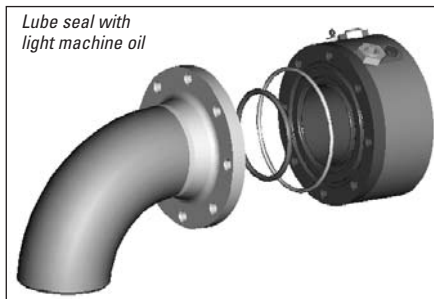

Step 5: Inspect and clean all machined surfaces. Press new static environmental and main seals into sealing grooves on swivel module tail.

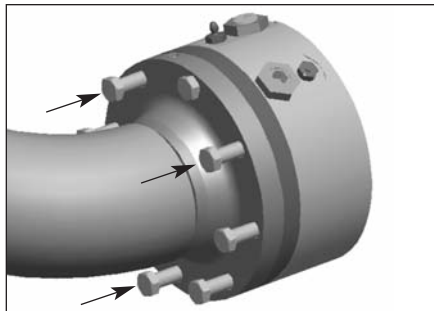

Note: Corrosion on any sealing surface may indicate need for component replacement.

Step 6: Align flange with body and press surfaces together. Thread flange bolts with Nord-Lok™ washers into tail and torque to amount shown on chart. Nord-Lok™ washers come as an assembly bonded together from the factory. It is important that the correct orientation be preserved for proper function. There are two different serration patterns on each side of the washer, with two washers in an assembly. The coarser serrations must face inward and lock together, while the finer serrations face outward and engage the bolts and mounting surface.



Step 7: Press static seal into swivel body outer groove, followed by placing purge seal inside recess created by tail and

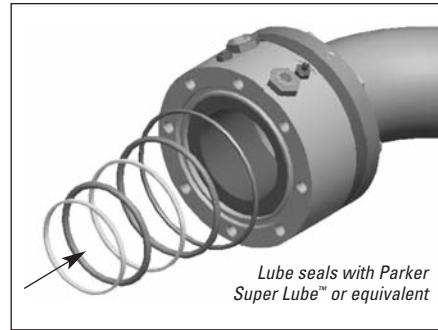

Lube seals with Parker Super Lube™ or equivalent

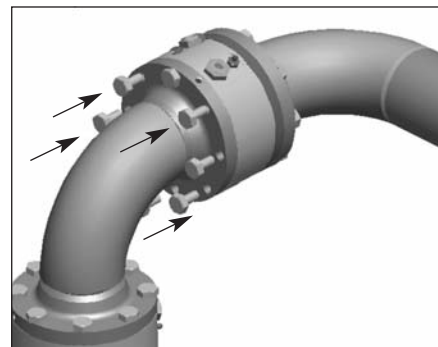

body. Set seal spacer ring inside purge seal, followed by main seal. Set SST smooth bore ring inside main seal, then cap entire seal/spacer combination with sealing flange. Torque bolts to specified value.

Suggested Maintenance Schedule

SWIVEL INSPECTION – Monthly

General Inspection for ease of rotation and evidence of leakage. Any evidence of problem would indicate a need for further maintenance.

SWIVEL LUBRICATION – Annually

It is recommended that each swivel module be lubricated with appropriate lubricant on an annual basis with manual grease gun.

SEAL REPLACEMENT – Every 2 years

Replacing swivel seals with appropriate swivel seal kit should be performed every 24 months, or at first evidence of leakage.

OVERHAUL – Every 4 years

Complete overhaul of swivel module should be performed every 48 months, or at evidence of leakage into bearing module. This process would involve seal replacement AND complete disassembly of swivel module to inspect raceways and replace dynamic environmental seal.

BOLT TORQUE CHART	2"	3"	4"
Torque (ft-lbs)	28	28	75
Torque (Nm)	38	38	102

It is generally good practice to perform a complete swivel inspection/rebuild (overhaul) every 24 months. This helps ensure trouble-free operation without interruption of your process. It is also advisable to rebuild at evidence of product leakage into bearing module.

Exercise caution so as not to lose any balls when removing them from the swivel module during disassembly. Flushing the grease chamber with a suitable, non-flammable solvent will allow the balls to fall out freely. Be sure the same number of balls are returned to each raceway.

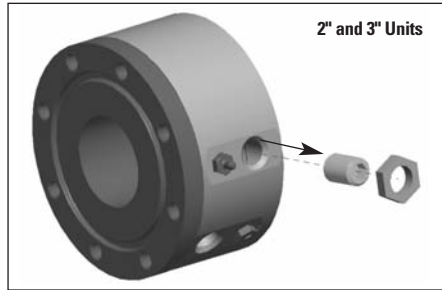

Step 1: Remove bearing plug bolts to access respective ball race.

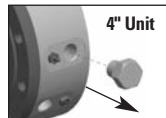

NOTE: 4" units are provided with threaded hex bolt in lieu of threaded plug/jam nut combination.

Step 2: Remove ball bearings via ball port in swivel body. NOTE: Non-flammable solvent may be used to help loosen lubricant and allow for easier ball removal.

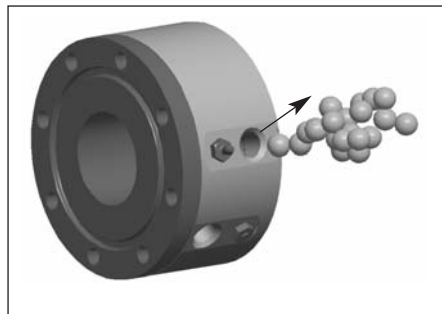

Step 3: After all balls have been removed carefully, remove swivel tail from swivel body.

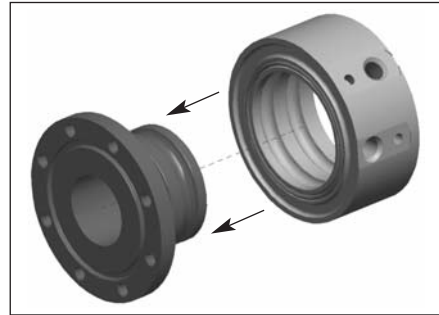

Step 4: Carefully remove dynamic environmental seal. Clean and inspect all machined surfaces and carefully press new environmental seal into groove. NOTE: Lube seal with light machine oil.

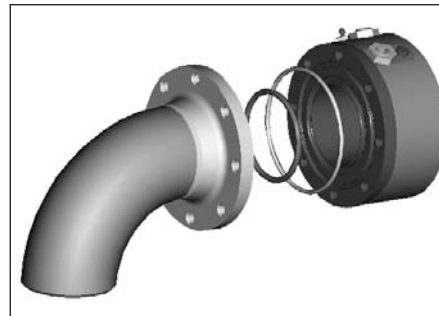

Step 5: Carefully align swivel tail and insert into body.

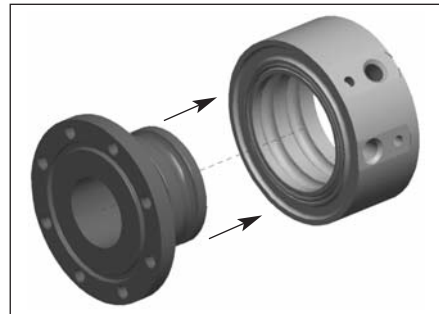

Step 6: Install ball bearings until bearing chamber is full. Chart below shows the number of bearings per race.

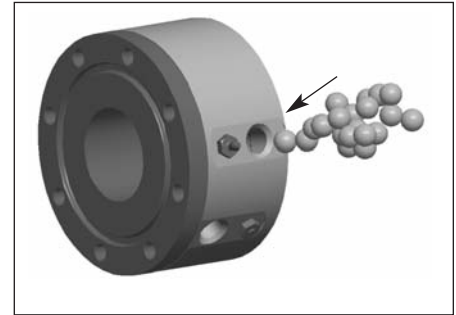

BEARINGS CHART	2"	3"	4"
Ball Bearings (qty.)	21	26	28

Step 7a: (2" and 3") With chamber completely full of bearings, rotate body/tail until one bearing is directly in-line with the threaded ball plug hole. Install the ball bearing plug and tighten down until it is just snug on the ball bearing. Then install the jam nut. Loosen the ball bearing plug by $\frac{1}{2}$ to $\frac{3}{4}$ of a turn and tighten jam nut.

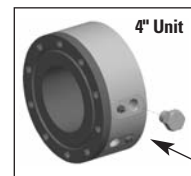
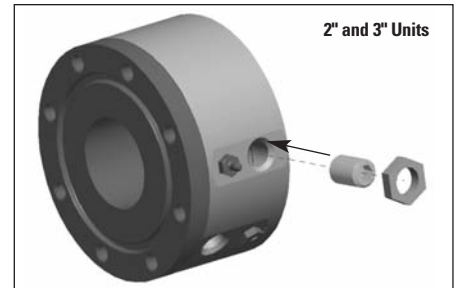

Step 7b: (4") With chamber completely full, install bearing plug bolt and tighten down all the way.

Step 8: Repeat Step 5 through Step 7 from DSF Seal Replacement instructions.

WARNING

Failure to follow these warnings could result in serious personal injury, property damage or product failure.

1) Do not attempt any maintenance service while the equipment is in operation. System pressure must be relieved and the product drained before attempting any service on the unit. The line must be locked out while service is in progress. If swivel is part of a loading arm, all torsion spring pre-load must be removed prior to disassembly.

2) OPW® products do not eliminate possible exposure to hazardous substances. The conditions of handling and use are beyond our control, and we make no guarantee and assume no liability for damages or injuries related to the use of our products. Follow the safety precautions outlined in the Material Safety Data Sheets for the material being used. It is the responsibility of the user to comply with all federal, state and local regulations. Always employ proper safety precautions and handling techniques.

3) Proper seal and wetted material part selection is critical for safe operation. To assure maximum life for the service intended, use only those materials compatible with the fluids being handled. Please note material being supplied and make certain that it is suited for the intended service.

MAIN AND BACK-UP SEALS

	Min Temp (F/C)	Max Temp (F/C)
Buna-N 1500	-20°F/-28.8°C	212°F/100°C
Fluorocarbon	-20°F/-28.8°C	400°F/204.4°C
PTFE (PFA) encapsulated Silicone (FDA Approved)	-50°F/-45.6°C	500°F/260°C
EPDM	-50°F/-45.6°C	250°F/121°C
Kalrez®	0°F/-17.7°C	500°F/260°C

All Endura™ DSF Swivels come standard with specified main and back-up seals. PTFE encapsulated Fluorocarbon environmental seals (qty. 2) and Static product seals (qty. 1) are standard. Other seals available upon request.

SEAL KITS

Size/DIN	Buna-N 1500	Fluoro-carbon	PTFE/Silicone	EPDM	Kalrez®
2" / DN 50	8400RK-0201	8400RK-0202	8400RK-0203	8400RK-0204	8400RK-0209
3" / DN 80	8400RK-0301	8400RK-0302	8400RK-0303	8400RK-0304	8400RK-0309
4" / DN 100	8400RK-0401	8400RK-0402	8400RK-0403	8400RK-0404	8400RK-0409

All Endura™ DSF Seal Kits include (2) Main seals, (1) Back-up seal and (3) PTFE encapsulated Fluorocarbon environmental seals. Also included are required seal spacers and hardware.

LUBRICANTS

Product	Description
H32132M	<p>High Performance Synthetic Lubricant (14 oz. (400 grams) cartridge)</p> <ul style="list-style-type: none"> • Specially formulated to reduce friction and wear • Will not drip, melt or carbonize • Compatible with all seal materials • Complies with FDA regulation 21CFR178.3570 • Requires only annual lubrication • Temperature range -40°F - 750°F (-40°C - 398.8°C)

 **Warning:** EPDM Seals require the use of a non-petroleum based lubricant. Must use OPW Synthetic Lubricant (Part Number H32132M) for all swivels provided with EPDM Seals.

IMPORTANT: OPW products should be used in compliance with applicable federal, state, provincial, and local laws and regulations. Product selection should be based on physical specifications and limitations and compatibility with the environment and materials to be handled. OPW MAKES NO WARRANTY OF FITNESS FOR A PARTICULAR USE. All illustrations and specifications in this literature are based on the latest product information available at the time of publication. OPW reserves the right to make changes at any time in prices, materials, specifications and models and to discontinue models without notice or obligation.